

REV NO	DETAILS	DATE	DRAWN/REV.BY	CHECKED BY	APPROVED BY
-	-	-	-	-	-

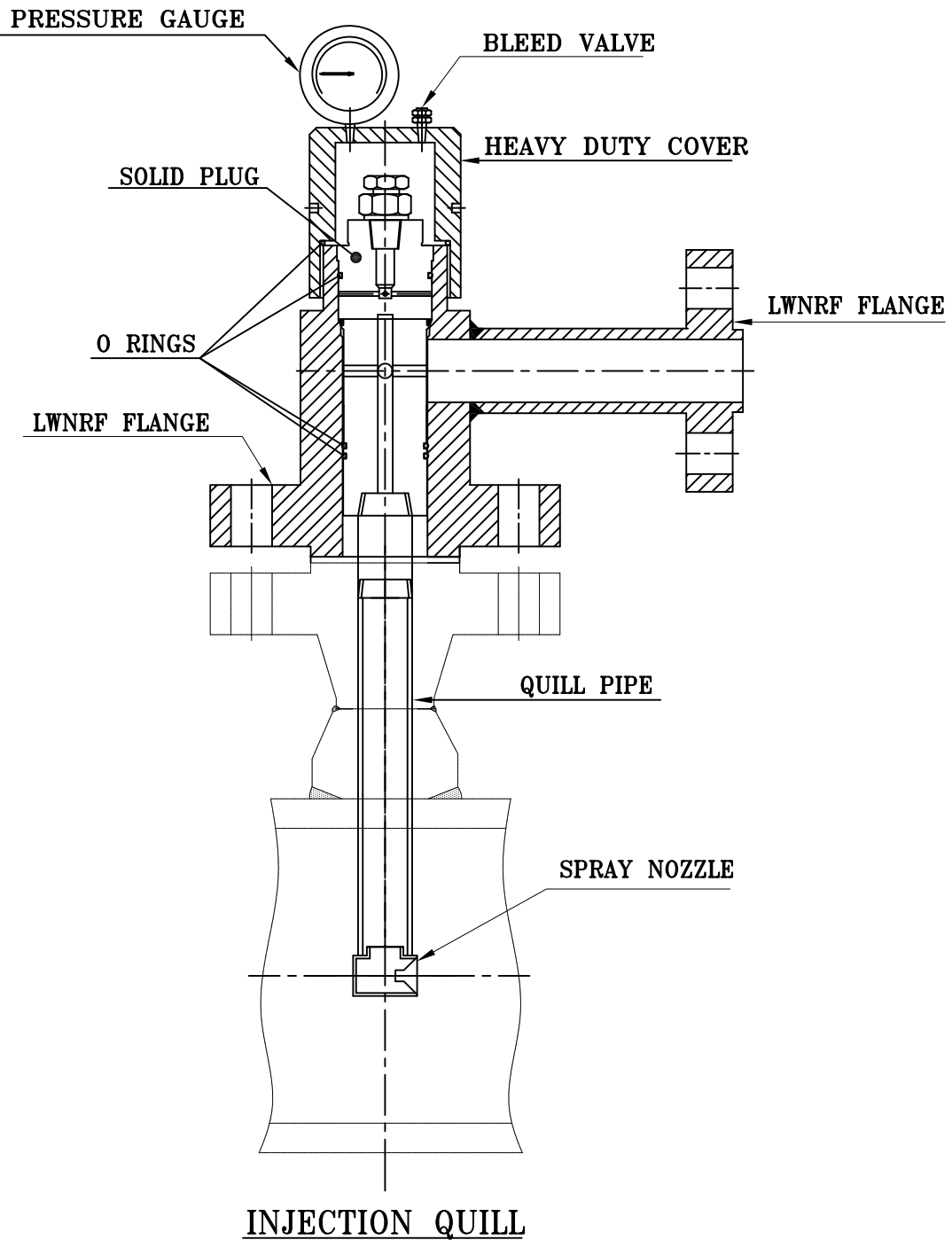

UNSPECIFIED TOLERANCE FOR MACHINING AS PER DIN 7168 CL. MEDIUM
UNSPECIFIED TOLERANCE FOR WELDING AS PER DIN 8570 DEG. OF ACCURACY B.

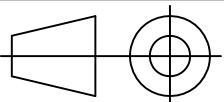

MANUFACTURER :-
CRYSTAL INDUSTRIAL SYNDICATE PVT. LTD
-TALOJA WORKS

SURFACE FINISH SYMBOLS	
Symbol	Roughness (CLA) Microns
	0.4 TO 0.8
	0.8 TO 1.6
	1.6 TO 4.0
	4.0 TO 8.0
	8.0 TO 25.0
	Machining after welding
	Commercial finish Produce by Casting, Forging & Flame Cutting. Burrs & Projections removal.

STAGE INSPECTION BY : -
CERTIFIED FOR CONSTRUCTION SIGN. :
DATE :
DEPT. : -

ACCESS FITTINGS WITH INJECTION QUILL		
CISPL JOB NO.	DRAWING NO.	REV.
-	-	-

THIS DRAWING & DESIGN IS THE PROPERTY OF CRYSTAL INDUSTRIAL SYNDICATE PVT. LTD AND MUST NOT BE COPIED OR LENT WITHOUT THEIR PERMISSION IN WRITING.

SCALE : -